

DESCRIPTION:

The 1003 Super Bright series is solid state lamps encapsulated in 10mm diameter package, and is most suitable for outdoor application requiring very high brightness.

The semi-conductor materials used are:

- GaAlAs for (1003HR3C)
- GaP for (1003VGC/VGD/VGT)
- GaAsP/GaP for (1003VYC/VYD/VYT)
- AlGaInP for (1003RS1C, 1003UO1D)

ABSOLUTE MAXIMUM RATINGS: (Ta=25°C)

Reverse Voltage	5 Volt
Reverse Current (Vr =5V)	100µA
Operating Temperature Range	-40°C To 85°C
Storage Temperature Range	-40°C To 100°C
Lead Soldering Temperature (1.6mm (1/16)From Body)	260°C For 5 Seconds

- NOTES : 1. All dimensions are in millimeters.
 2. Lead spacing is measured where the leads emerge from the package.
 3. Protuded resin under flange is 1.5 mm (0.059") Max.
 4. Specifications are subject to change without notice.

PACKAGE DIMENSIONS

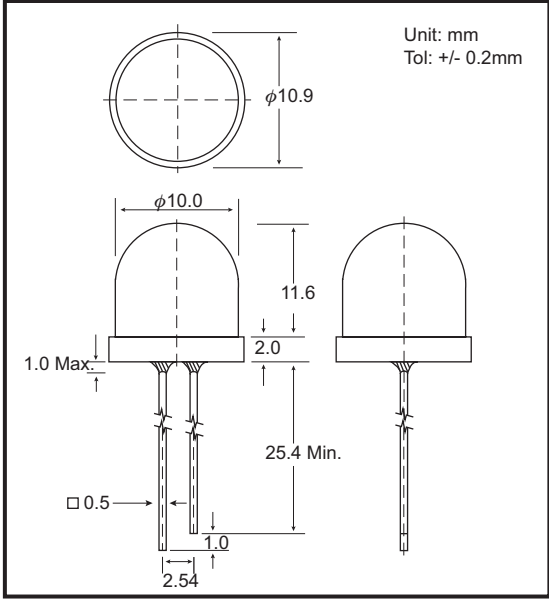

PART NO. SELECTION AND APPLICATION INFORMATION (RATINGS AT 25°C AMBIENT)

Part No.	Emitted Color	Lens Color	Peak Wavelength λp (nm)	Vf (v)		Rec. If (mA).	Iv (mcd)		View Angle 2θ1/2(Deg)
				Min	Max		Min	Typ.	
GB-1003RS1D	Super Red	Red Diffused	635	1.5	2.6	10-20	5.0	70.0	90
GB-1003UY1D	Ultra Yellow	Yellow Diffused	590	1.7	2.6	10-20	120.0	150.0	90
GB-1003UO1D	Amber	Orange Diffused	620	1.7	2.6	10-20	170.0	200.0	90
GB-1003VGT	Super Green	Green Trans.	565	1.7	2.6	10-20	10.0	25.0	20
GB-1003VYT	Super Yellow	Yellow Trans.	585	1.7	2.6	10-20	10.0	25.0	20
GB-1003HR3C	Super Red	Water Clear	660	1.5	2.6	10-20	300.0	700.0	20
GB-1003VGC	Super Green	Water Clear	565	1.7	2.6	10-20	10.0	25.0	20
GB-1003VYC	Super Yellow	Water Clear	585	1.7	2.6	10-20	10.0	25.0	20

TESTING CONDITION FOR EACH PARAMETER :

PARAMETER:	SYMBOL	UNIT	TEST CONDITION
REVERSE VOLTAGE	Vr	VOLT	Vr = 5.0 Volt If = 20mA
REVERSE CURRENT	Ir	µA	
FORWARD VOLTAGE	Vf	VOLT	
LUMINOUS INTENSITY	Iv	MCD	If = 20mA
VIEWING ANGLE	2θ1/2	DEGREE	
RECOMMENDED OPERATING CURRENT	If (Rec)	mA	

