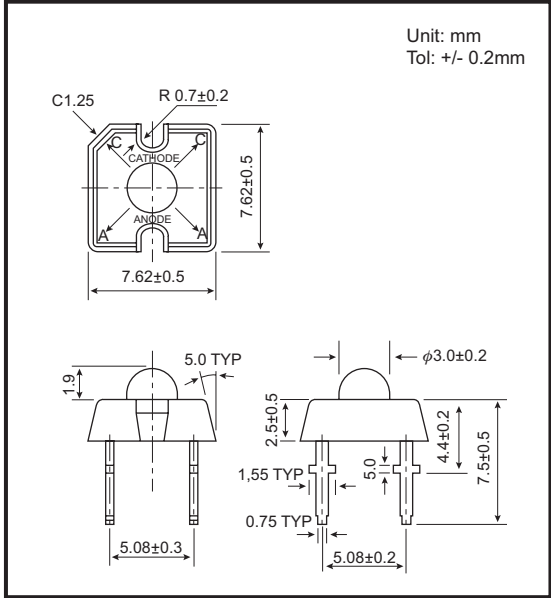

DESCRIPTION:

The U46 series is used under high current operation with low thermal resistance. The efficient optical design and high current capacities provide a more uniform and unique illuminated appearance. This series is most suitable for automotive exterior lighting and signal sign.

AlGaInP for (U46RS3C, U46RTSC, U46UY3C, U46YTSC, U46UO3C)
 InGaN for (U46B472C, U46BG2C)

PACKAGE DIMENSIONS

ABSOLUTE MAXIMUM RATINGS: (Ta=25°C)

Reverse Voltage	5 Volt
Reverse Current (Vr =5V)	100µA
Operating Temperature Range	-40°C To 85°C
Storage Temperature Range	-40°C To 100°C
Lead Soldering Temperature (1.6mm (1/16)From Body)	260°C For 5 Seconds

- NOTES : 1. All dimensions are in millimeters.
 2. Lead spacing is measured where the leads emerge from the package.
 3. Protuded resin under flange is 1.5 mm (0.059") Max.
 4. Specifications are subject to change without notice.

PART NO. SELECTION AND APPLICATION INFORMATION (RATINGS AT 25°C AMBIENT)

Part No.	Emitted Color	Lens Color	Peak Wavelength λp (nm)	Vf (v)		Rec. If (mA).	Iv (mcd)		View Angle 2θ1/2(Deg)
				Min	Max		Min	Typ.	
GB-U46RS3C	Ultra Red	Water Clear	635	1.7	2.6	20	250	500	70
GB-U46RTSC	Ultra Red	Water Clear	635	2.0	2.8	20	500	1000	70
GB-U46UY3C	Ultra Yellow	Water Clear	590	1.7	2.6	20	240	500	70
GB-U46YTSC	Ultra Yellow	Water Clear	590	2.0	2.8	20	400	880	70
GB-U46UO3C	Ultra Orange	Water Clear	620	1.7	2.6	20	200	450	70
GB-U46BG2C	Bluish Green	Water Clear	505	2.8	4.0	20	500	1000	70
GB-U46PG2C	True Green	Water Clear	525	2.8	4.0	20	500	1000	70
GB-U46B472C	Blue	Water Clear	470	2.8	4.0	20	140	300	70

TESTING CONDITION FOR EACH PARAMETER :

PARAMETER:	SYMBOL	UNIT	TEST CONDITION
REVERSE VOLTAGE	Vr	VOLT	Vr = 5.0 Volt
REVERSE CURRENT	Ir	µA	If = 20mA
FORWARD VOLTAGE	Vf	VOLT	If = 20mA
LUMINOUS INTENSITY	Iv	MCD	If = 20mA
VIEWING ANGLE	2θ1/2	DEGREE	
RECOMMENDED OPERATING CURRENT	If (Rec)	mA	

