

Features:

- High intensity
- Standard T-1 3/4 diameter package
- Wide viewing angle
- General purpose leads
- Reliable and rugged

Part NO.	Lens Color	Source Color
GB-333UV1C/L1	Water Clear	Violet

Notes:

1. All dimensions are in millimeters (inches).
2. Tolerance is $\phi 0.25$ (.010")mm unless otherwise noted.
3. Protruded resin under flange is 1.0mm (.04") max
4. Lead spacing is measured where the leads emerge from the package.
5. Specifications are subject to change without notice.
6. Caution in ESD: Static Electricity and surge damages the LED.
It is recommend to use a wrist band or anti-electrostatic glove when handling the LED. All devices, equipment and machinery must be properly grounded.
7. Specifications are subject to change without notice.

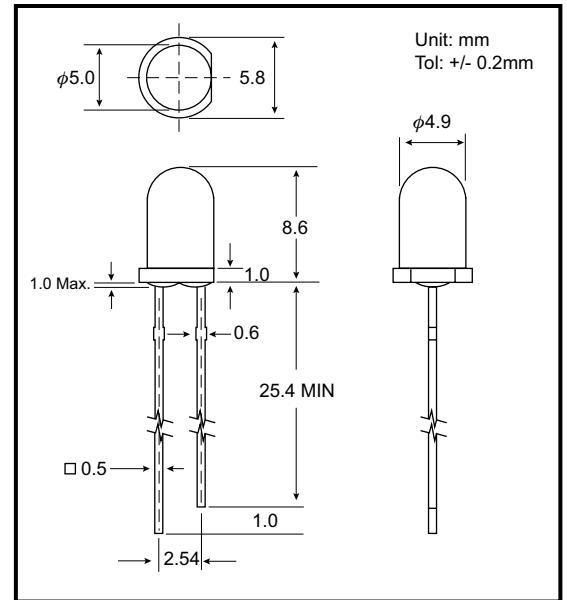
PACKAGE DIMENSIONS

Absolute Maximum Ratings at Ta=25°C

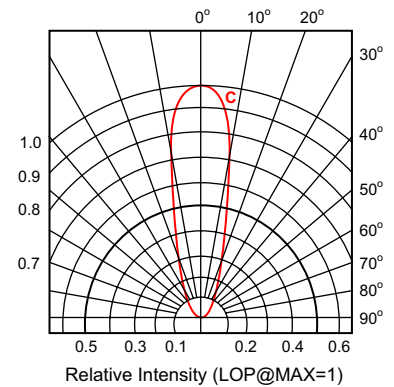
Parameter	MAX.	Unit
Power Dissipation	100	mW
Peak Forward Current (1/10 Duty Cycle, 0.1ms Pulse Width)	100	mA
Continuous Forward Current	35	mA
Derating Linear From 50°C	0.4	mA/°C
Reverse Voltage	5	V
Operating Temperature Range	-40°C to +80°C	
Storage Temperature Range	-40°C to +80°C	
Lead Soldering Temperature [4mm (.157") From Body]	260°C for 5 Seconds	

Electrical Optical Characteristics at Ta=25°C

Parameter	Symbol	Min.	Typ.	Max.	Unit	Test Condition
Luminous Intensity	Iv	---	290	---	mcd	If=20mA (Remark 1)
Viewing Angle	2 θ 1/2	20	25	30	Deg	(Remark 2)
Peak Emission Wavelength	λ_p	---	405	---	nm	If=20mA
Dominant Wavelength	λ_d	---	430	---	nm	If=20mA (Remark 3)
Spectral Line Half-Width	$\Delta\lambda$	11	16	21	nm	If=20mA
Forward Voltage	V _F	2.8	3.7	4.5	V	If=20mA
Reverse Current	I _R	---	---	100	mA	V _R =5V

Remarks:

1. Luminous intensity is measured with a light sensor and filter combination that approximates the CIE eye-response curve.
2. θ 1/2 is the off-axis angle at which the luminous intensity is half the axial luminous intensity.
3. The dominant wavelength (λ_d) is derived from the CIE chromaticity diagram and represents the single wavelength which defines the color of the device.